

Note:
 This Detail is Typical for Heating Systems
 and Chilled Water Systems w/o Glycol
 See Valve and Fitting Installation Detail for Additional Requirements

Detail : Chilled Water Expansion Tank & Chemical Feed System (w/o Glycol)

No Scale

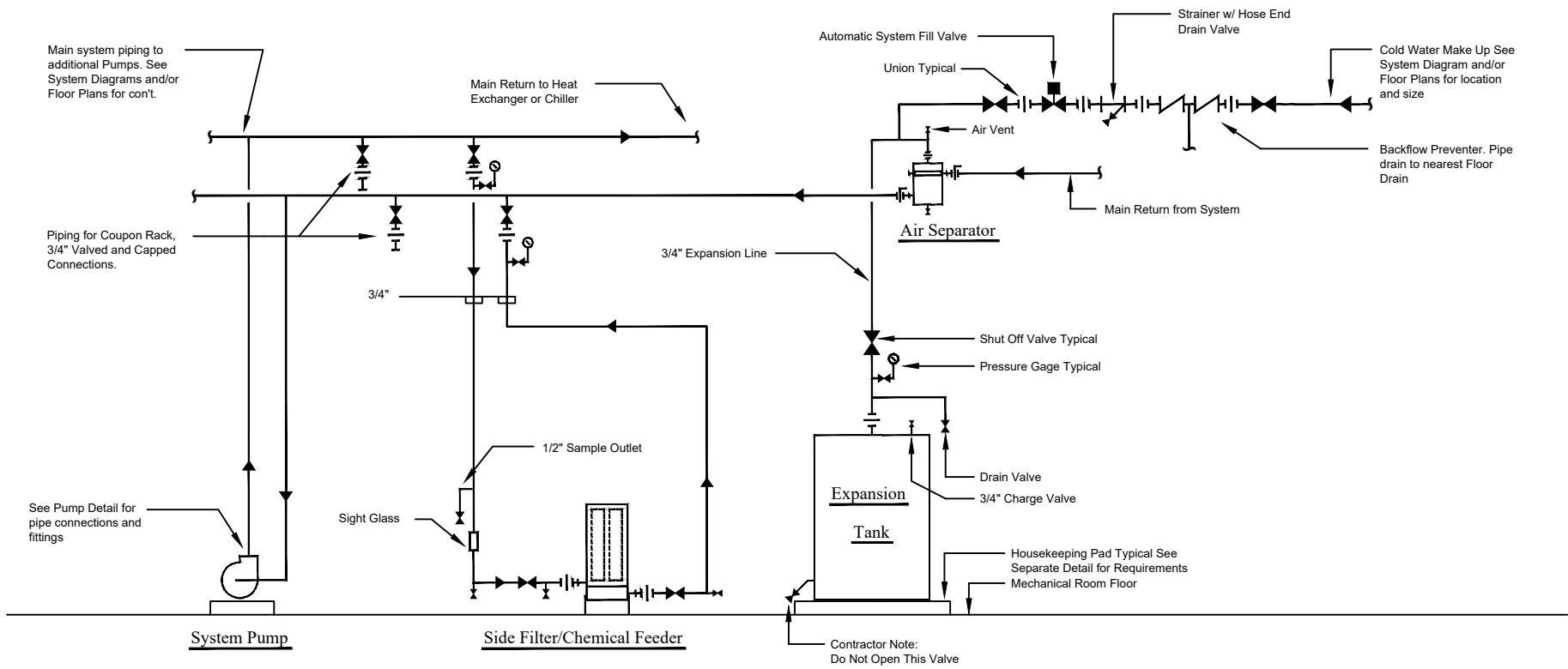

Note:
 This Detail is Typical for Heating Systems
 and Chilled Water Systems w/o Glycol
 See Valve and Fitting Installation Detail for Additional Requirements

Detail : Heating Water Expansion Tank & Side Filter / Chemical Feed System (w/o Glycol)

No Scale